

PRODUCTION RELEASE & REVISION						
REV	DESCRIPT'N/BUYER	DWG No	PARTS No.	BY	CHK	DATE
A	INITIAL / ALLBRAND	-----	50301815	Y.YKIM	N.C.PARK	08-17-M4

FASTRAX II KEYBOARD CONTROLLER

Instruction Manual



Manual Label Name
(50201073: 120x30mm)

*Please read this manual thoroughly before use and keep it handy for future reference.
Rev.040130*

280(+/-5)mm

215(+/-5)mm

BUYER BRAND TYPE (LABEL : 50201073)

BRAND	MODEL No.:	30mm
	POWER	
	ADDRESS	
120mm		

ex) HITRON TYPE

HITRON	Model No.: HID2404CLN
	DC 12V \equiv 0.5A
HITRON SYSTEMS INC. 109-19 MAJEON-RI, SAMJUK-MYEON, ANSUNG-CITY, KYUNGKI-DO, 456-880 KOREA	

NOTES

- MODEL: HID2404CLN/P, HID2404CZN/P - ALL BRAND
- MATERIAL: ART PAPER 100g/m², WHITE
BIND : STAPLES-2
- FINISH: -----
- COLOR: TEXT-BLACK
- SIZE: 215(+/-5)mm x 280(+/-5)mm R: 0.0
- ANY CHANGE OR ALTERNATION MUST BE APPROVED BY HITRON ENGINEERING.

협	전자	안전규격	기구설계	CS
의	정용석	김성곤		
	08.17.M4	07.09.M4		

50301815

UNLESS OTHERWISE SPECIFIED ALL DIMENSIONS ARE IN MM. - TOLERANCE		APPROVALS	DATE	PARTS LIST	
LABEL	+/- 1.5	N.C.PARK	08-17-M4	 TITLE MANUAL INSTRUCTION	
MANUAL	+/- 3.5				
ANGULAR	+/- 0.5	CHKED		SIZE	A4
MATERIAL	2	DRAWN	Y.YKIM	DWG No	-----
FINISH			08-17-M4	P/N	-----
				SCALE	DO NOT SCALE

FASTRAX II KEYBOARD CONTROLLER

Instruction Manual



Please read this manual thoroughly before use and keep it handy for future reference.

Rev.040130

WARNING AND CAUTION

WARNING

TO REDUCE THE RISK OF FIRE OR ELECTRIC SHOCK, DO NOT EXPOSE THIS PRODUCT TO RAIN OR MOISTURE. DO NOT INSERT ANY METALLIC OBJECTS THROUGH THE VENTILATION GRILLS OR OTHER OPENINGS ON THE EQUIPMENT.

CAUTION

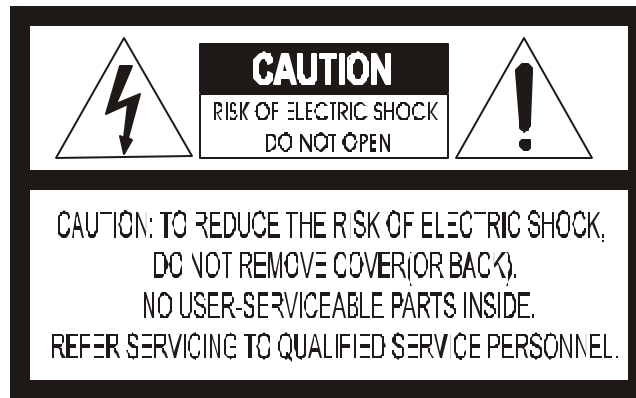

EXPLANATION OF GRAPHICAL SYMBOLS



The lightning flash with arrowhead symbol, within an equilateral triangle, is intended to alert the user to the presence of uninsulated "dangerous voltage" within the product's enclosure that may be of sufficient magnitude to constitute a risk of electric shock to persons.



The exclamation point within an equilateral triangle is intended to alert the user to the presence of important operating and maintenance (servicing) instruction in the literature accompanying the product.

FCC COMPLIANCE STATEMENT

FCC INFORMATION: THIS EQUIPMENT HAS BEEN TESTED AND FOUND TO COMPLY WITH THE LIMITS FOR A CLASS A DIGITAL DEVICE, PURSUANT TO PART 15 OF THE FCC RULES. THESE LIMITS ARE DESIGNED TO PROVIDE REASONABLE PROTECTION AGAINST HARMFUL INTERFERENCE WHEN THE EQUIPMENT IS OPERATED IN A COMMERCIAL ENVIRONMENT. THIS EQUIPMENT GENERATES, USES, AND CAN RADIATE RADIO FREQUENCY ENERGY AND IF NOT INSTALLED AND USED IN ACCORDANCE WITH THE INSTRUCTION MANUAL, MAY CAUSE HARMFUL INTERFERENCE TO RADIO COMMUNICATIONS. OPERATION OF THIS EQUIPMENT IN A RESIDENTIAL AREA IS LIKELY TO CAUSE HARMFUL INTERFERENCE IN WHICH CASE THE USER WILL BE REQUIRED TO CORRECT THE INTERFERENCE AT HIS OWN EXPENSE.

CAUTION: CHANGES OR MODIFICATIONS NOT EXPRESSLY APPROVED BY THE PARTY RESPONSIBLE FOR COMPLIANCE COULD VOID THE USER'S AUTHORITY TO OPERATE THE EQUIPMENT.

THIS CLASS A DIGITAL APPARATUS COMPLIES WITH CANADIAN ICES-003.

CET APPAREIL NUMÉRIQUE DE LA CLASSE A EST CONFORME À LA NORME NMB-003 DU CANADA.

CE COMPLIANCE STATEMENT

WARNING

THIS IS A CLASS A PRODUCT. IN A DOMESTIC ENVIRONMENT THIS PRODUCT MAY CAUSE RADIO INTERFERENCE IN WHICH CASE THE USER MAY BE REQUIRED TO TAKE ADEQUATE MEASURES.

IMPORTANT SAFEGUARDS

1. Read these instructions.
2. Keep these instructions.
3. Heed all warnings.
4. Follow all instructions.
5. Do not use this apparatus near water.
6. Clean only with dry cloth.
7. Do not block any ventilation openings. Install in accordance with the manufacturer's instructions.
8. Do not install near any heat sources such as radiators, heat registers, stoves, or other apparatus (including amplifiers) that product heat.
9. Do not defeat the safety purpose of the polarized or grounding-type plug. A polarized plug has two blades with one wider than the other. A grounding type plug has two blades and a third grounding prong. The wide blade or the third prong are provided for your safety. If the provided plug does not fit into your outlet, consult an electrician for replacement of the obsolete outlet.
10. Protect the power cord from being walked on or pinched particularly at plugs, convenience receptacles, and the point where they exit from the apparatus.
11. Only use attachments/accessories specified by the manufacturer.
12. Unplug this apparatus during lightning storms or when unused for long periods of time.
13. Refer all servicing to qualified service personnel. Servicing is required when the apparatus has been damaged in any way, such as power-supply cord or plug is damaged, liquid has been spilled or objects have fallen into the apparatus, the apparatus has been exposed to rain or moisture, does not operate normally, or has been dropped.
14. CAUTION - THESE SERVICING INSTRUCTIONS ARE FOR USE BY QUALIFIED SERVICE PERSONNEL ONLY. TO REDUCE THE RISK OF ELECTRIC SHOCK DO NOT PERFORM ANY SERVICING OTHER THAN THAT CONTAINED IN THE OPERATING INSTRUCTIONS UNLESS YOU ARE QUALIFIED TO DO SO.
15. Use Certified/Listed Class 2 power supply transformer only.

Table of Contents

Chapter 1. INTRODUCTION	6
1.1 Features	6
1.2 Unpacking	7
Chapter 2. INSTALLATION	8
2.1 Connection Diagram	8
2.2 Termination & Dip Switch Setting	13
2.3 Multiplexer Control	14
2.4 Keyboard Setup	15
2.5 Master & Slave Keyboard Setting	16
2.6 Install with ADR series	17
2.7 Install with SDR series	20
2.8 Install with IDR series	23
Chapter 3. OPERATION	26
3.1 Keyboard Lock/Unlock.....	26
3.2 Controlling Multiplexer	26
3.2 Summary of Keyboard Control.....	28
Appendix A Trouble Shooting.....	32
Appendix B SPECIFICATION.....	32

Chapter 1 INTRODUCITON

1.1 Features

This keyboard controller is capable to control 32 Fastrax II dome cameras and remote control functions for variety of external switching devices like Multiplexer(max 255), Digital Video Recorder(max 99) etc...

The keyboard controller features:

- The capability of control a camera's panning and tilting movement with variable speed from 0.5 °/sec to 90°/sec as well as its zoom, focus, and iris command. Normal speed is inversely proportional to the current zoom ratio. Turbo speed is Max 380°/sec when **Ctrl** key pressed.
- The ability to define and recall up to 240 **presets**, which are immediate camera call-ups of preset position view, with automatic zoom and focus.
- The ability to define and run up to 8 **patterns**, which comprise a sequential series of pan, tilt, zoom, and focus movements from a single camera.
- The ability to define and run up to 8 **scans**, which scan between two limits.
- The capability to incorporate up to 300 of the presets, patterns, scan and tour itself in up to 8 **tours**, where the presets, patterns and scan automatically displayed one after the other on the Main monitor.
- **Global preset** recalls preset of all dome cameras.
- Auto Iris mode activated by moving the joystick slightly.
- Auto Focus mode is activated by twisting the zoom handle slightly.
- Programmable user preferences (alarm, preset, title, etc.).
- Administrator and user, two levels of password are supported for higher security.
- One Master and slave Keyboard is supported to control in a distant place.
- Multiplexers (Max 255) and DVR system (Max 99) can be controlled remotely.
- Up to two programmed data from domes can be downloaded to none volatile memory space in KBD, and uploads to a new dome.
- **There are two type of controller which has professional joystick with zoom handle or simple economic joystick.**

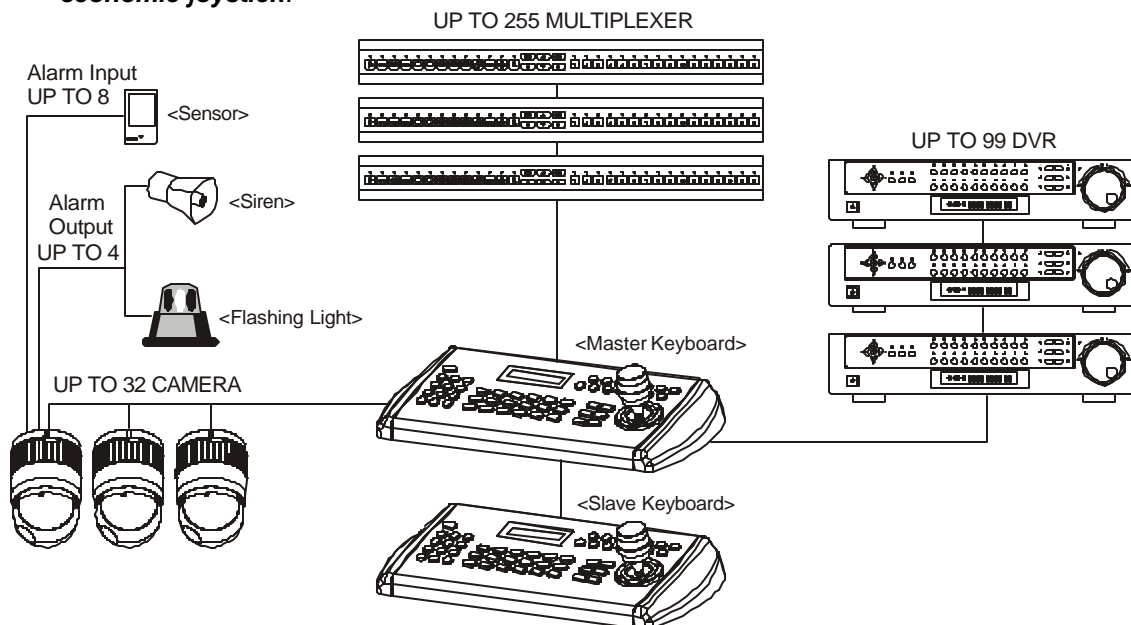

Figure 1 – Typical system Configuration

1.2 Unpacking

Unpack the equipment and make sure all listed items are included in the box.

Contents of Keyboard box

Keyboard controller -----	1
Junction box -----	1
3m cable -----	2
M4 Self tapping screws -----	4
Instruction manual -----	1
12VDC SMPS -----	1

Chapter 2 INSTALLATION

2.1 Connection Diagram

2.1.1 Basic Installation Diagram

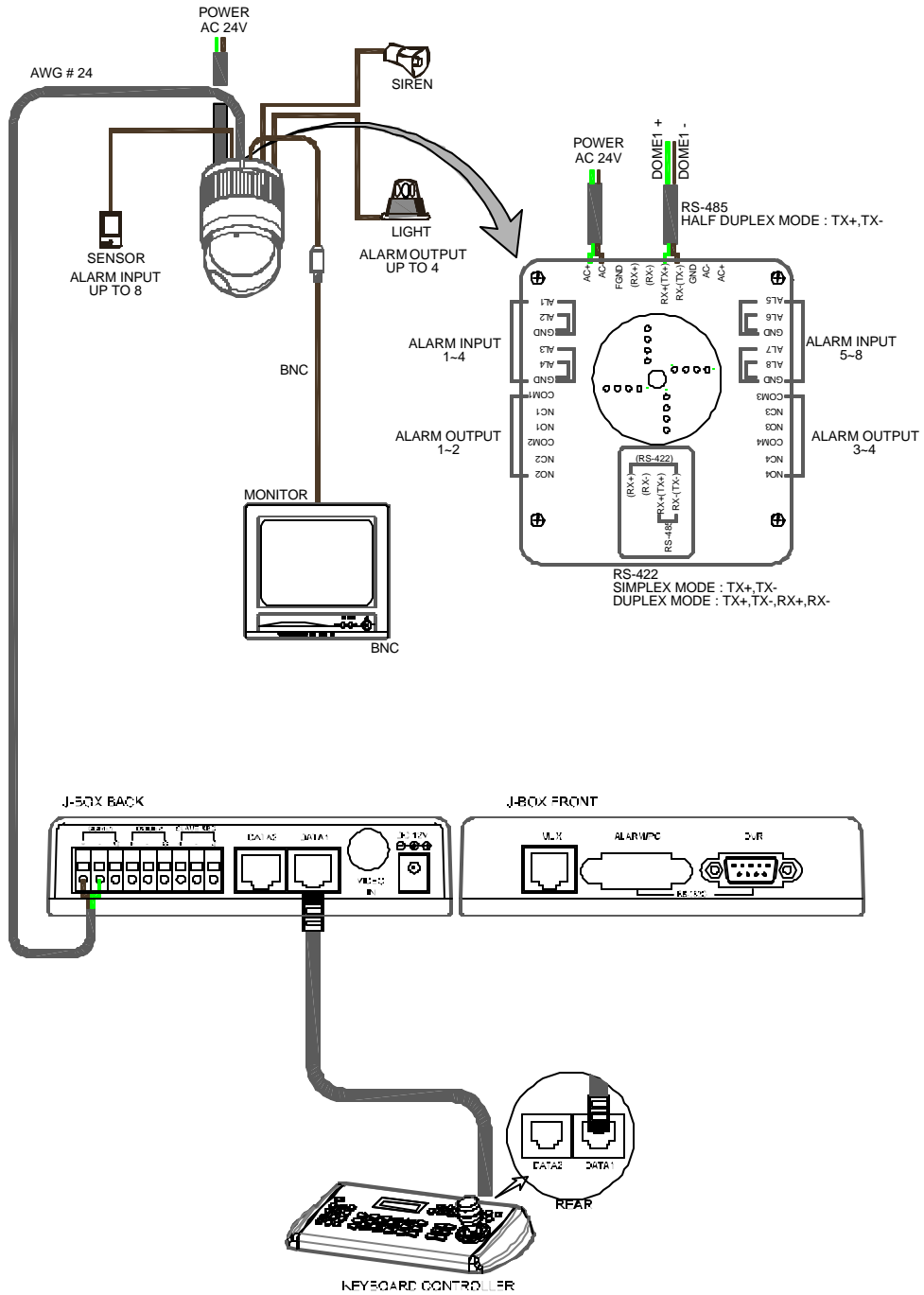

Figure 2 – Basic installation diagram

2.1.3 Single User with Two Multiplexer

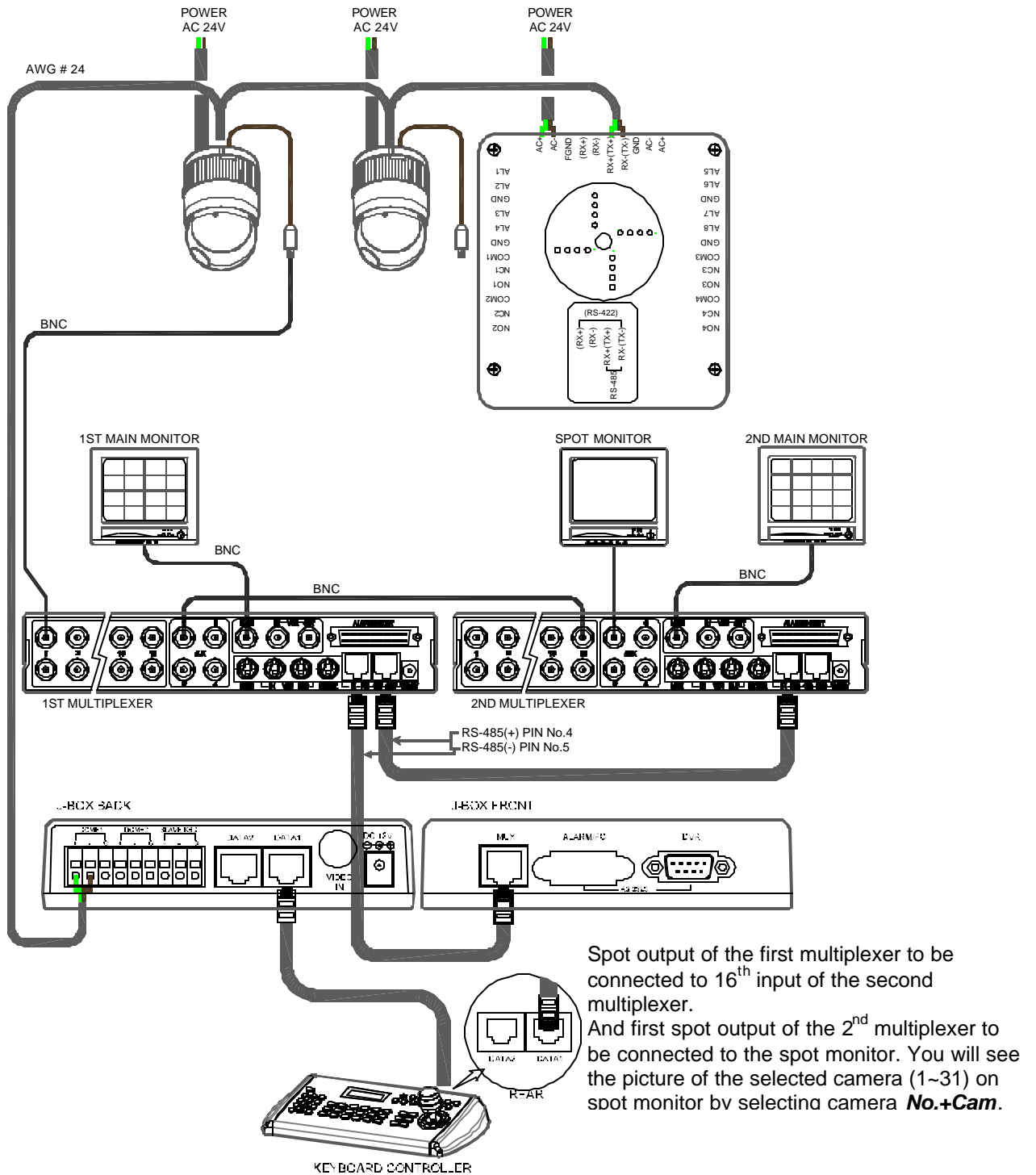
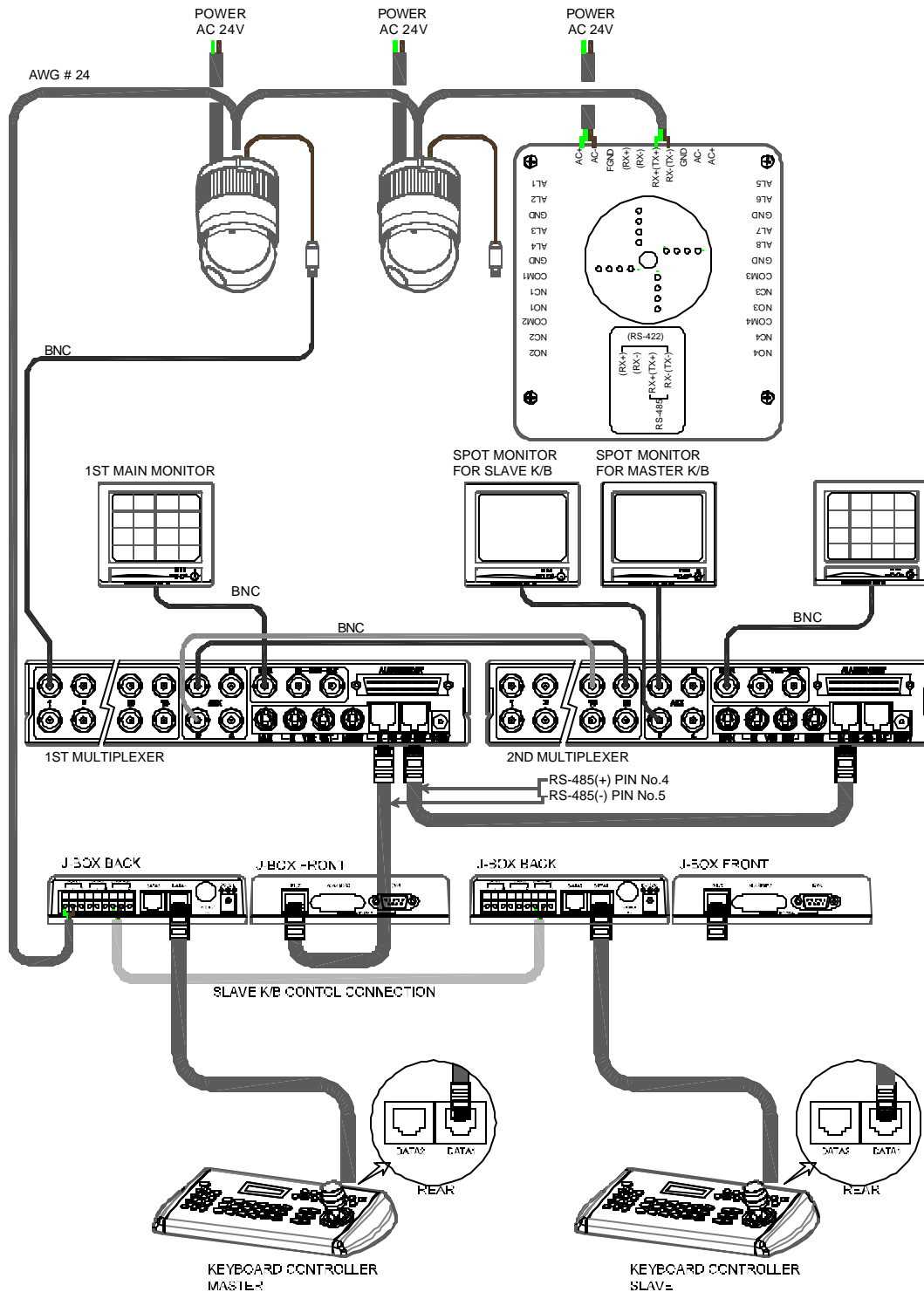

Figure 4 – Two Multiplexer

2.1.4 Two Multiplexer with Slave Keyboard Controller



Spot output 1 of the first multiplexer to be connected to 16th input of the second multiplexer. n: User, Spot out of nth to be connected to (15-n)th camera input of the 2nd multiplexer. nth spot out of the 2nd multiplexer to be connected to the nth use spot monitor. Each user will see the picture of the selected camera (1-(31-n)) on nth spot monitor of the Mux 2 by selecting camera **No.+Cam**.

2.1.5 Two Multiplexer with Slave Keyboard Controller(method 2)

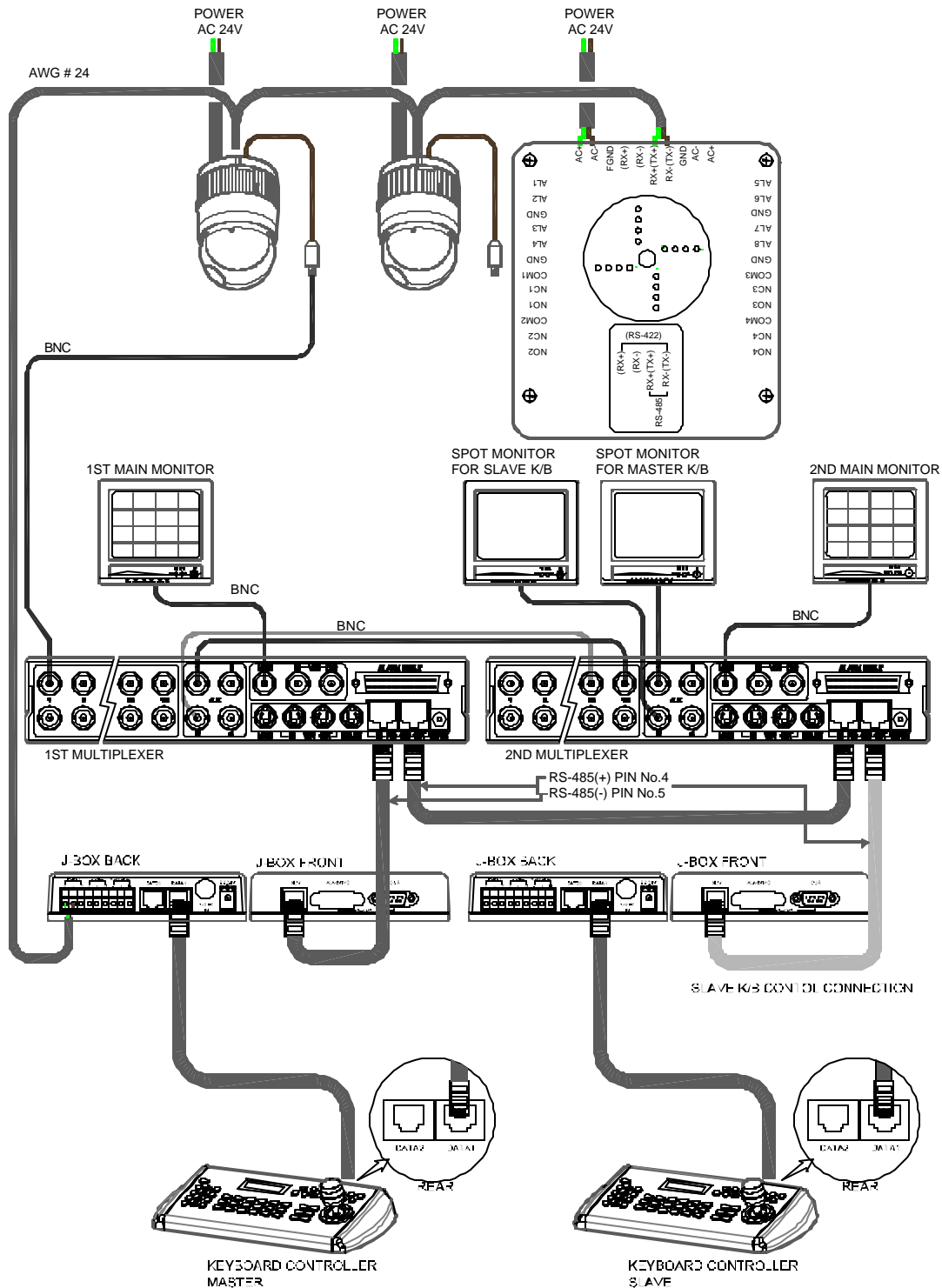

Figure 5 – Two Multiplexer with Slave Keyboard Controller

Spot output 1 of the first multiplexer to be connected to 16th input of the second multiplexer. n: User, Spot out of nth to be connected to (15-n)th camera input of the 2nd multiplexer. nth spot out of the 2nd multiplexer to be connected to the nth user spot monitor. Each user will see the picture of the selected camera (1~(31-n)) on nth spot monitor of the Mux 2 by selecting camera **No.+Cam.**

2.2 Termination & Dip Switch Setting

The first and last devices in an installation (dome and keyboard controller) must have the data line terminated by setting the DIP switch. Without proper termination, there is potential for control signal errors. Total length of the cable for communication should not exceed 1 mile. Refer to Figure 7 for setting the dome camera and keyboard controller termination.

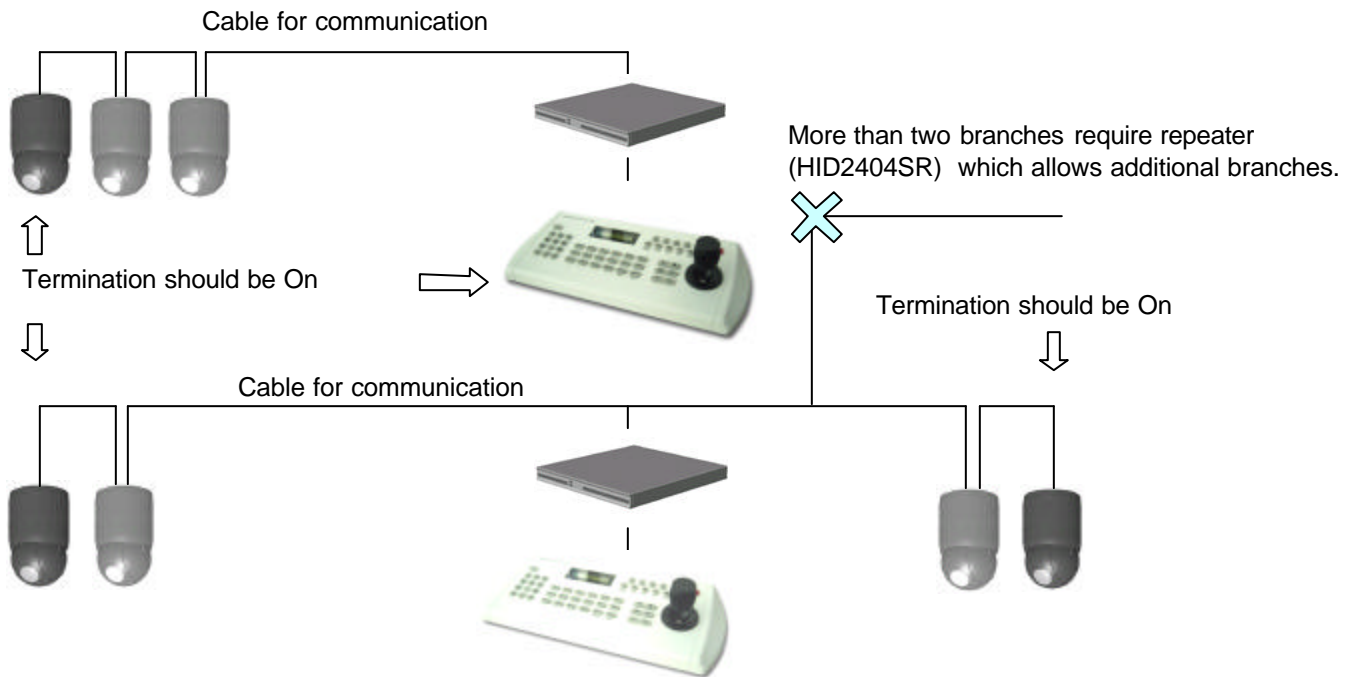

Figure 7 – Termination and ID Switches.

Termination and Master/Slave: Set the switches according to your configuration.

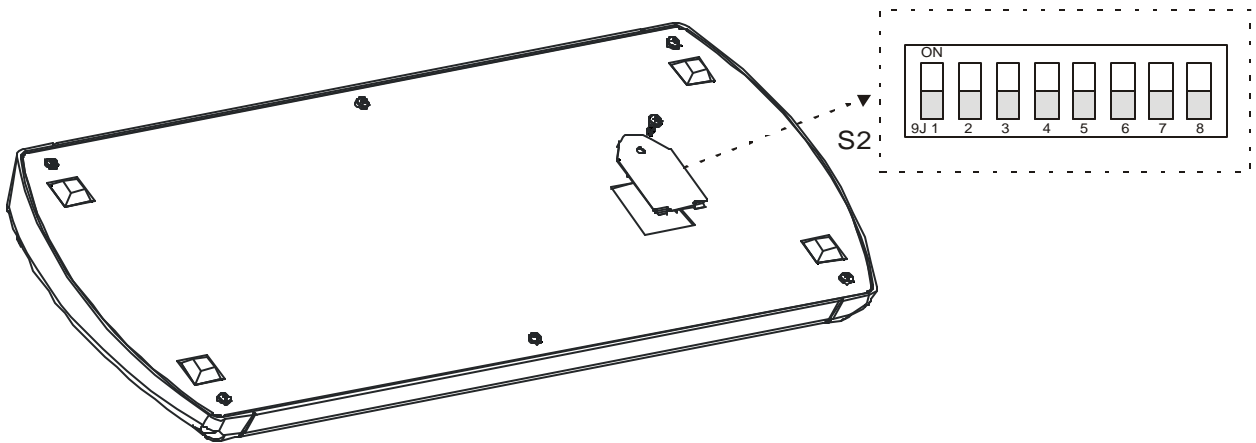

Figure 8 – Keyboard DIP Switches

Termination	DOME	Multi- plexer	Sub- controll er				Controller		
	1	2	3	4	5	6	7	8	
ON	ON	ON	ON	reserved			SLAVE	ON	Factory Use
OFF	OFF	OFF	OFF				MASTER	OFF	

Table 1 - S1 Switch Setting

2.3 Multiplexer Control

- **Duplex setup:**

NOTE: Multiplexers require a new ROM version to be controlled by the keyboard controller. The new multiplexer ROM accepts control instructions from the keyboard controller. If your multiplexer's serial number is **M104xxxx** or higher, then it is ready to accept control instructions. Alternately, you can check the status of your multiplexer by pressing the Menu key of the multiplexer and then selecting item 9. If you see the "*** Protocol" option line in the Communication Setup menu, your multiplexer has the new ROM, and you do not need to replace the ROM. If your multiplexer has the old ROM version, contact your distributor on how to get new a ROM.

CAUTION: Before opening the multiplexer, make certain you are working on an antistatic work surface and that you are wearing a grounding wrist strap. Also, be very careful to orient the ROM chip correctly and not bend any of the pins.

NOTE: Replace the multiplexer firmware with the new multiplexer ROM (U45) as follows; Remove the top cover of the multiplexer, and locate the **ROM (U45)**. Before removing the ROM, note the orientation of the ROM. After removing the old ROM from the socket, insert the new ROM. Be careful to orient the new ROM the same as the old ROM. (Refer to the Multiplexer instruction manual.)

Set the multiplexer functions as follows:

(Press the Menu key of the multiplexer to enter the Unit Options menu.)

9. Unit Options
 Unit Number: 001 (first Mux) or 002 (second Mux)
 Communication Type: RS 485
 Baud rate: 9600 bps
 PORT: ON

** Protocol:** B (If you see this line, the multiplexer has the new ROM)

** The old ROM version does not show Protocol selection option.

Multiplexer alarm inputs will function normally, but the Dome controller has no way of knowing about alarms wired to the Multiplexer. If a Dome preset is required for such an alarm, you must connect the same alarm input to both the multiplexer and Dome.

- **Triplex setup:** Unit setup
 Network Type: RS 485
 Baud Rate: 9600 bps
 Unit address: 001 ~ 128
 Protocol: B1

2.4 Keyboard Setup

User need to setup network, passwords and special functions such as Uploading and Downloading programmed data from the dome cameras. To enter the Keyboard menu, press **Ctrl + Menu**. You will see the following menu. Joystick Up/Down scrolls menu items, push the stick to Right to enter the sub-menu.

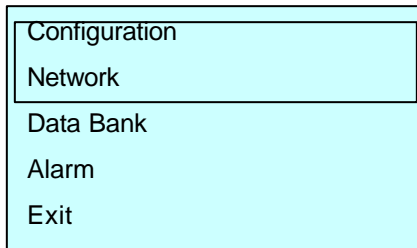

Configuration

- Key Beep : ON - enable key beep sound,
OFF - Disable beep sound.
- Key-Lock : OFF~60Min - After elapsed setup time, keyboard lock automatically.
OFF - Disable Auto Key-Lock function.
User needs login password to operate Keyboard again.
- Chg User Pin - Change 4digit of user password.
CurrentPin : Enter 4 digits of current user's password.
NewPin : Enter 4 digits of new password.
ConfirmPin : Confirm 4 digits of new password.
- Chg Admin Pin - Change 4 digits of administrator's password.
CurrentPin : Enter 4 digits of new password.
NewPin : Enter 4 digits of new password.
ConfirmPin : Confirm 4 digits of new password.

**Note) Factory default Administrator's password is 9999+Enter and user password is 1111+Enter.
If you forgot your own password, contact service personnel or distributor.**

- Rescan Domes Scan newly installed dome cameras without turn off the Keyboard power.
- Save and Exit Save the programmed data and return to the previous Menu
(Exit without saving if you press ESC key)

Network Setup properties of devices to be connected.

- Set Baud rate
Dome : 2400~230K Correspond with dome setting (9600bps)
MUX : 2400~230K
DVR485 : 2400~230K
DVR232 : 2400~230K
Save and Exit
- Com Ports Select the device to be connected on selected port.
Dome : None/Dome ...
MUX : None/DUPLEX/TRIPLEX/AUX IN/AUX I/O...

DVR485 : None/ADR/SDR/IDR/AUX IN/AUX I/O...
 DVR232 : None/ADR/SDR/IDR/AUX IN/AUX I/O...
 Save and Exit Save the programmed data and return to the previous Menu
 (Exit without saving if you press **ESC** key)

Note) AUX IN : auxiliary signal input (simplex mode)
AUX I/O : when auxiliary signal input , respond to the signal (Half duplex mode)

- Set Slave kbd
 - Slave kbd : ON/OFF ON- Slave KBD exit, OFF- Not exist.
 - MUX control : ON/OFF Set accessibility of the multiplexer menu at slave keyboard
 - Dome Menu: ON/OFF Set accessibility of the dome camera menu at slave keyboard
 - Release :INF/001~200s INF (Infinite) - Slave Keyboard user never have the control right of the dome which is selected by master Keyboard users
 1 ~ 200s(Second) - After elapse of programmed time since master Keyboard user use the dome, slave Keyboard user can get the control right of the dome.
 - Save and Exit Save the programmed data and return to the previous Menu
- Exit
- Data Bank - Up/Download saved data of the dome
 - DataBank 1 : 001 001— Data from Dome ID 001 is exist on Bank 1
 - Upload If you are sure to upload or clear data to the selected dome then
 - Clear Data press **Enter** key, **ESC** key to cancel and exit.
 - DataBank 2 : Empty
 - DownLoad If you are sure to download data from the selected dome then
 - Exit Press **Enter** key, **ESC** key to cancel and exit.
- Alarm
 - Alarm Check : ON/OFF Whether K/B check the alarm input of domes or not.
 On : 32 domes, Off : 64 dome cameras supported.
 - Alarm Beep : ON/OFF When dome' s alarm, beep sound on or off
 - Exit

2.5 Master & Slave Keyboard setting

You can use two keyboards at distant site.

Master keyboard should be setup as following procedure.

1. Check for dip switch the 7th of S2 "OFF".
2. Press **Ctrl + Menu**. Check Slave KBD setting "ON". (Network Set Slave Kbd Slave kbd: ON/OFF)

Slave keyboard need to setup as following procedure.

1. Check for dip switch the 7th of S2 "ON".
2. If you setup all connection correctly (See Figure 4) and turn on slave keyboard, you can see following screen.

FASTRAX-2L Vxxx
 Slave ID = 1
 Input Password : xxxx
 CAM:000

Current Device ID = 1
 Default setting is **9999** for administrator **1111** for user
 000 means that controller is not connected to master keyboard

3. Press **Ctrl + Menu**. Set the Slave ID to 01
4. Set Slave Node to "B" in case that master keyboard model is HID2404CLx(N : NTSC,P : PAL) and to "B" in case HID2404CDx

Slave ID = 1
 Slave Node : A/B

A : HID2404CLx or HID2404CZx , B : HID2404CDx

2.6 Install with ADR series

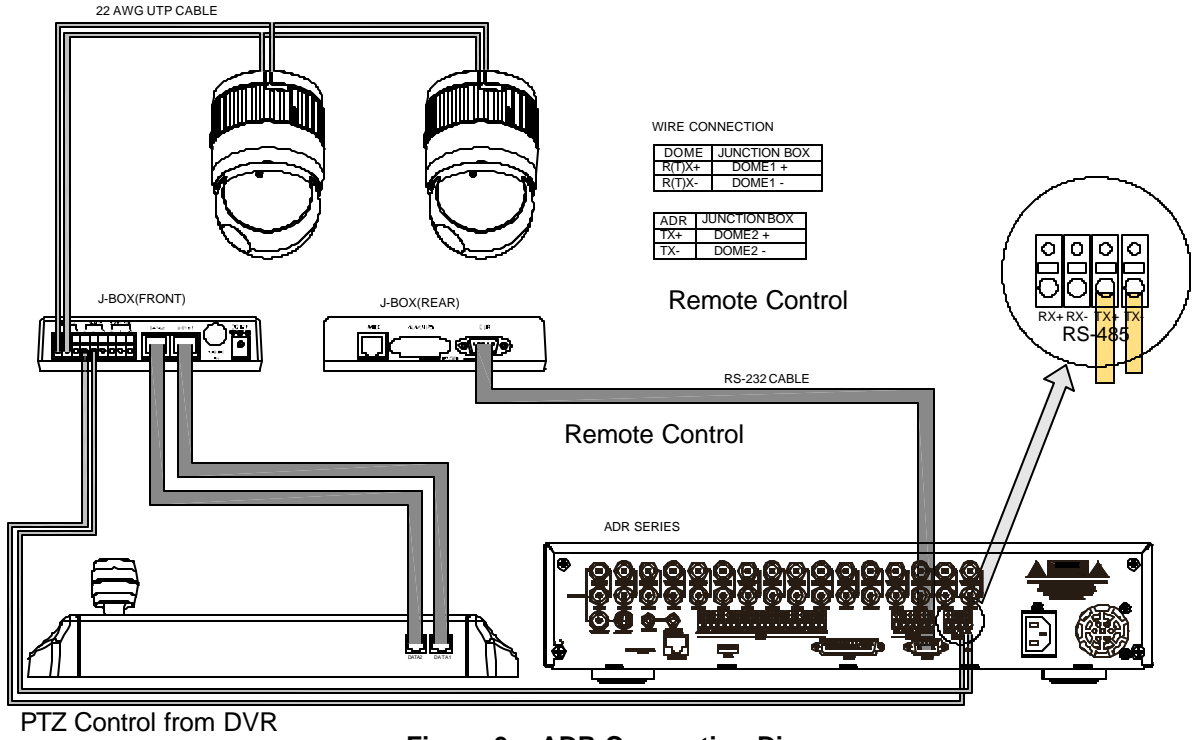

Figure 9 – ADR Connection Diagram

- If user wants to connect with ADR, proceed as the following order.
- 1) Connect RS232 cable between RS-232 Port of ADR and DVR port of the J-box. (This connection enables ADR control remotely from KBD controller)
 - 2) Connect wires between the TX(+/-) of ADR and Data2(+/-) of J-Box. (This connection enables ADR PTZ control from the keyboard controller)

- 3) How to setup the controller.
 - A. Switch the keyboard controller ON
 - B. Input password (Factory setting is **9999**)
 - C. Open the menu of the keyboard controller by pressing **Ctrl + Main** Key.
 - D. Set as below in Network menu.

Set Baud Rate	
Dome	: 9600
Mux	: 9600
DVR485	: 9600
DVR232	: 9600
Com Port	
Dome	: Dome
Mux	: None
DVR485	: AUX IN
DVR232	: ADR

- 4) How to setup ADR
 - Switch the ADR on.
 - Press the Menu button. Input password according to the instruction. (Factory setting is **4321**)
 - If the below screen is appeared, set "Quick Setup" to "Off".

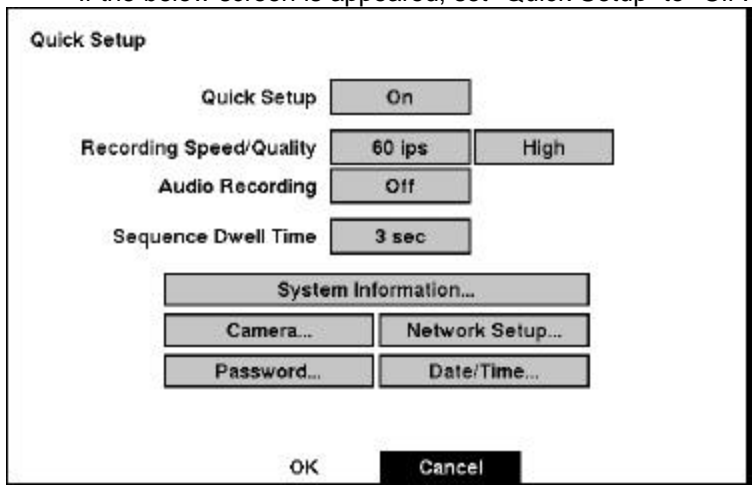

Press "OK", and the below screen will be appeared.

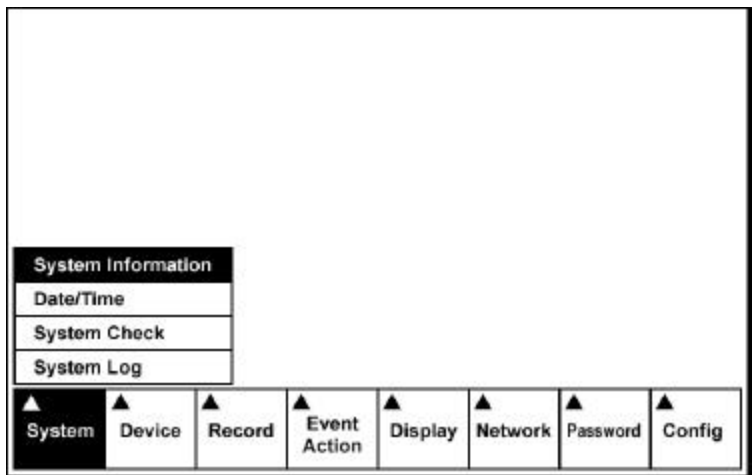

Select "System Information" on the system menu and change UNIT ID.

System Information Change

Site Description

Unit ID

Language **English**

- English
- Français
- Deutsch
- Italiano
- Español

OK Cancel

Select "Camera" on the Device menu.
Unit ID should be 1 up to 99. Unit ID is not allowed number "0".

Camera

Camera	On/Off	Title	PTZ Device	ID
1	On	CAM1	None	
2	On	CAM2	None	
3	On	CAM3	None	
4	On	CAM4	None	

OK **Cancel**

Set "PTZ Device" and "ID" of the dome camera.
Select RS232/RS485 after PTZ is installed, and then set-up as below table.

RS232/RS485

RS232/RS485	Baud Rate	Parity	Data	Stop	Usage
RS232	9600	None	8	1	External Modem
RS485	57600	None	8	1	Remote Control

OK **Cancel**

RS232/RS485	Baud Rate	Parity	Data	Stop	Usage
RS232	9600	None	8	1	Remote Control
RS485	9600	None	8	1	PTZ Control

- 5) After setting Unit ID, Camera, and RS232/RS485, installing dome camera is basically completed. Please refer to the manual of ADR for the other installation.
- 6) Press the related number of the controller which is correspondent to unit ID of ADR. Then press DVR button and adjust unit ID of the controller
- 7) Make sure if any change is appeared on screen when you press  button of the controller for basic testing. If there's no change appeared, verify cable connection and setting of installation.

2.7 Install with SDR series

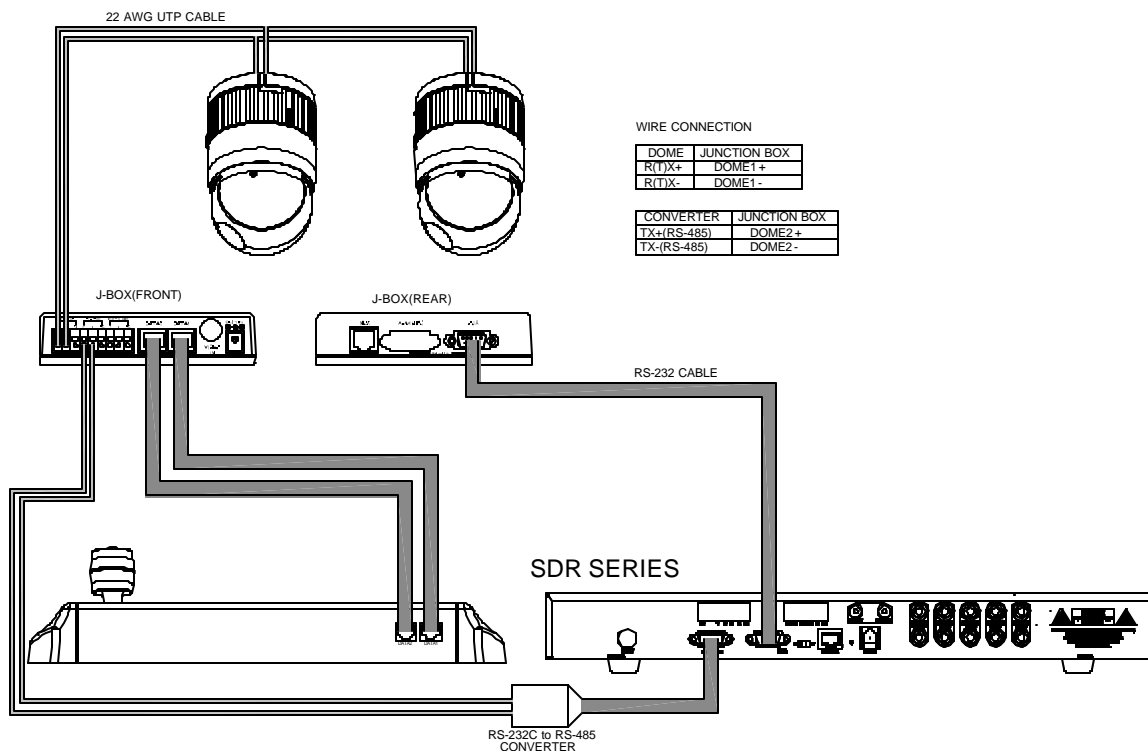

Figure 10 – SDR Connection Diagram

If user wants to connect with SDR, proceed as the following order.

- 1) Connect RS-232 cable between RS-232C Port of SDR and DVR port of the J-box. (This connection enables SDR control remotely from KBD controller)
- 2) Plug the RS-232C TO RS-485 converter in the RS-232C Port of SDR. Connect wires between the TX(+/-) of converter and Data2(+/-) of J-Box.
(This connection enables ADR PTZ control from KBD controller)
- 3) How to setup the controller.
 - A. SWITCH THE KBD controller ON
 - B. INPUT PASSWORD (Factory Setting is **9999**)
 - C. Open the menu of the KBD controller by pressing **Ctrl + Main** Key.

D. Set as below in Network menu.

Set Baud Rate	
Dome	: 9600
Mux	: 9600
DVR485	: 9600
DVR232	: 9600
Com Ports	
Dome	: Dome
Mux	: None
DVR485	: AUX IN
DVR232	: SDR

4) How to setup SDR

- Switch the SDR on.
- Press the Menu button. Input password according to the instruction. (Factory setting is **4321**)
- If the below screen is appeared, set "Quick Setup" to "Off".



If press OK after putting Quick Setup to off status, the below screen will be appeared. Besides, the below screen will be appeared according to installation status.

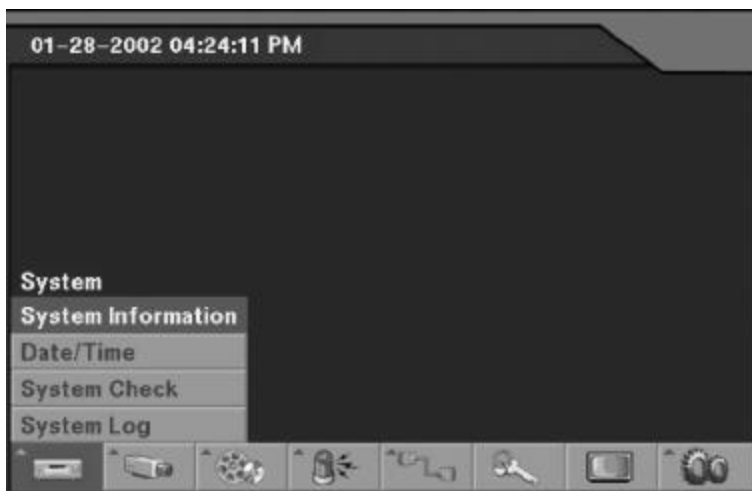

Select Camera of Device menu on the above menu.



PTZ set up on the above Setup menu

Select TEXT IN/PTZ after PTZ is installed, and then set-up as below



RS232/TEXT IN	Baud Rate	Parity	Data	Stop	Usage
RS232	9600	None	8	1	Remote Control
TEXT IN/PTZ	9600	None	8	1	PTZ Control

- 1) After installing Camera, and RS232 & TEXT IN/PTZ setup, the installation with dome camera is basically completed. Please refer to manual of SDR for the other installation.
- 2) Press the related number of a controller which correspondent to unit ID of SDR. Then press DVR button and adjust unit ID of a controller. Unit ID is not allowed number "0".
- 3) Make sure if any change is appeared on screen to press  button of a controller for basic testing. If there's no change appeared, check cable connection and installation again.

2.8 Install with IDR series

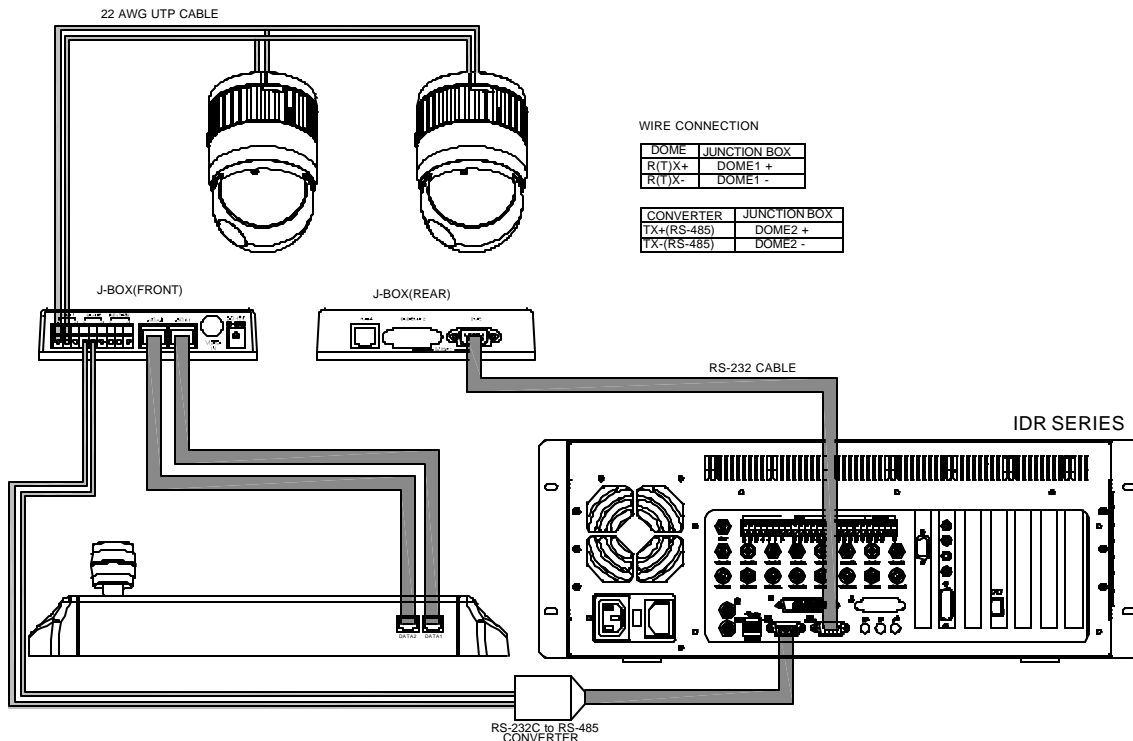

Figure 11 – IDR Connection Diagram

If user wants to connect with IDR, please proceed as the following order.

- 1) Connect RS-232C cable between RS-232C Port of IDR and DVR port of the J-box. (This connection enables IDR control remotely from KBD controller)
- 2) Plug the RS-232C TO RS-485 converter in the RS-232C Port of IDR. Connect wires between the TX(+/-) of converter and Data2(+/-) of J-Box.
(This connection enables IDR PTZ control from KBD controller)
- 3) How to setup the controller.
 - A. SWITCH THE KBD controller ON
 - B. INPUT PASSWORD (Factory Setting is **9999**)
 - C. Open the menu of the KBD controller by pressing **Ctrl + Menu** Key.
 - D. Set as below in Network menu.

Set Baud Rate	
Dome	: 9600
Mux	: 9600
DVR485	: 9600
DVR232	: 9600
Com Ports	
Dome	: Dome
Mux	: None
DVR485	: AUX IN
DVR232	: IDR

- 4) How to setup IDR

- Switch the IDR on.



If press setup button on the above screen, the below screen will be appeared.

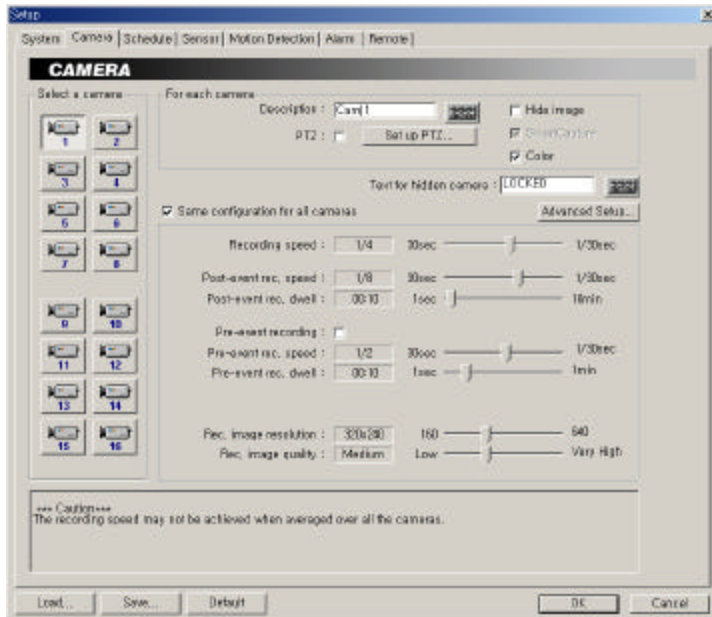

Select camera input number that dome camera connected. Then install as below to select set-up PTZ after checking PTZ box.

Port : COM2
 RX Device : Fastrax....
 Baud Rate : 9600
 Data : 8
 Parity : None
 Stop Bit : 1

If PTZ is not necessary for IDR, cable and installation here is not needed. (IDR is able to be controlled remotely and there's no PTZ function)

8) How to IDR Remote setup

- If selects Setup on main menu, the below screen will be appeared.

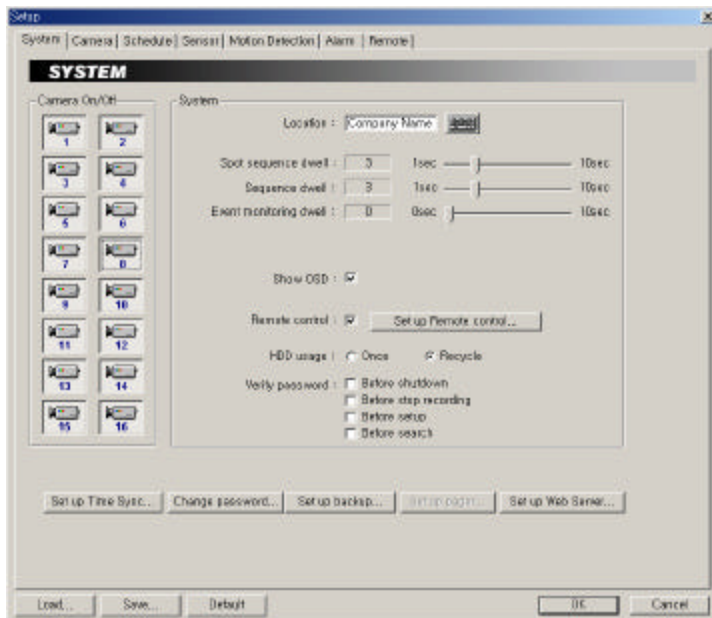

After selecting System and checking Remote control box, please install as below to select Setup remote control. Device ID is not allowed number "0".

Port : COM1
Baud Rate : 9600
Data : 8
Parity : None
Stop Bit : 1
Device ID : XX

- 3) Make sure if any change is appeared on screen to press **Ctrl + 9** (Next Screen) button of a controller for basic testing. If there's no change appeared, check cable connection and installation again.

Chapter 3 OPERATION

3.1 Keyboard Lock/Unlock (Hidden command)

When the user leaves the control desk, he may wish to lock the keyboard controller to prevent unauthorized use.

Pressing **777 + Enter** will lock the keyboard controller. Pressing **777 + Enter** while the keyboard is locked will open the password screen. If the correct password is entered, the keyboard controller will return to normal operation.

If the power is turned OFF and ON while the keyboard is locked, it will ask for the password. Entering the correct password will cause the keyboard controller to return to normal operation.

*** If you forget your own passwords, turn off the keyboard controller, contact distributor to get 4-digit back door password. This will change the passwords to the factory default **1111** and **9999**. Contact your service personnel to get 4-digit back door password.*

3.2 Controlling Multiplexer

Using a multiplexer allows more flexibility in the types of cameras that can be used in a full system. Dome cameras and regular cameras can be mixed.

The keys **PIP, 2x2, 3x3, 4x4, Zoom, Set**, etc., are keys that are used to operate the multiplexer. See Figure x for details.

3.2.1 Selecting Multiplexer

Duplexer : Press **Macro/Menu** key to enter Multiplexer set up menu and hold down the **Enter** Key while navigating using the joystick. (**Enter+Joystick**)

Triplexer : Push the **Joystick** to upward with **Enter** pressed (**Enter+Joystick**) will show the Mux menu. It will act like a mouse. Rotating the handle clockwise will act like the set key of the multiplexer. Rotating counterclockwise will act like the **ESC** key of the Multiplexer.

3.2.2 Dome Camera Selection

There are three types of dome camera selection, **No.+Cam**, **No.+Main** and **Prev** or **Next**. And with these selections, the keyboard controller has full control of the selected camera if it is a dome camera.

Single multiplexer configuration

By pressing the camera No. **1** to **16+ Cam**, you will see the picture of the selected camera through the spot monitor which connected to the spot output of the multiplexer.

Two multiplexer configurations

By pressing the camera No. **1** to **31 + Cam**, you can see the picture of the selected camera through the spot monitor which is connected to the spot output of the second multiplexer.

Spot output of the first multiplexer is connected to the 16th camera input of the second multiplexer.

For example, **1 + Cam** will switch the camera 1 to second multiplexer spot output. If the selected camera is a dome, the keyboard controller has control of it, and you can control all functions of the selected camera using the keyboard controller.

Pressing the **Next** or **Prev** keys will scroll through all connected dome cameras and display them on the Spot output.

Viewing full screen mode (m + Mux, n + Main)

Select cameras 1 to 16 by pressing the camera number and then Main. The selected camera will appear in the full screen mode and is under control if it was dome camera. Even if no camera is connected to the multiplexer input, the screen will show the camera input (see following example).

To select first multiplexer under control, press **1 + Mux** (m: ID of Mux – up to 128) successively

Multiplexer 1	Keyboard controller
1	1+ Main
2	2+ Main
.	
.	
15	15+ Main
16	16+ Main

This sequence (**No.+Main**) is same as pressing the 1, 2, 3...16 buttons on the multiplexer.

To select second multiplexer under control, press **2 + Mux**

when a second multiplexer is connected:

Multiplexer 2	Keyboard controller
1	1+ Main
2	2+ Main
3	3+ Main
.	
.	
16	16+Main

When using two multiplexer configuration, connect the main or spot output of the first multiplexer to the Camera 16 input of the second multiplexer.

If the spot output of the first multiplexer is connected to the Camera 16 input of the second multiplexer, you can see selected camera output through the spot output of second multiplexer by pressing camera No. (**1 to 31**) + **Cam** Successive camera call is valid on two Mux configuration only.

For example: **1+Cam** will switch camera 1 to the second multiplexer spot output and you can control all functions of the selected camera using the keyboard controller.

If you install more than two Multiplexers, the unit number (ID : up to 128) of the Multiplexer and selection of the Multiplexer must be the same in order to control the Multiplexer with the Keyboard.

Example: If the unit address (number, see page 15) of the Multiplexer is 128, you should press **128 + Mux** to control the 128th Multiplexer.

Picture on Spot output monitor (Camera No.1~16+Aux1~4)

Pressing Camera No. **1 to 16 + Aux1~ 4** will switch the selected camera number to the specific spot monitor output of the multiplexer. The selected camera can be a dome camera or a standard camera. The Keyboard controller maintains control of the previously selected dome camera. It does not change the main output of the multiplexer.

Example: m+Mux, n+AuxN m: ID of Mux, n: input No. of camera, N: spot output No.

1+MUX, 2+Aux1(~4) will switch camera 2 on multiplexer 1 to the spot output of multiplexer 1.



2+MUX, 3+Aux1(~4) will switch camera 3 on multiplexer 2 to spot output of multiplexer 2.

1+Cam will switch camera 1 to the spot output of multiplexer 1 and the keyboard controller has control of the selected camera.

In a two multiplexer configuration, **18+Cam** will switch camera 18 (second camera on Multiplexer 2) to the spot output of multiplexer 2 and the keyboard controller has control of the selected camera.

31+Cam = camera 15 of the second multiplexer.





3.3.1 Keys for Dome camera















Function	Key Label	Descriptions
1,2, ... 9,0	1,2, ... 9,0	Camera selection with Cam key. Function number selection with function keys. (e.g., 1+Cam, 3+Tour, 5+Scan, 6+Prst)
Camera	CAM	Displays the selected camera on the spot out of the multiplexer and allows the camera to be controlled by the keyboard controller, if the selected camera is a dome camera.
Full	MAIN	Camera No. 1~16+Main will display the selected camera full screen
Cancel	ESC	Cancels current inputs. Exits from currently running functions or menu, error status, etc.
Alarm	ALRM	Disregards all currently activated alarms and turns off the beep temporarily. If alarm is activated again within the programmed hold time, the timer will restart and beep again.
Relay ON	ON	Relay No. 1~4+ ON will activate the selected relay.
Relay OFF	OFF	Relay No. 1~4+ OFF will disable the selected relay.
Previous	PREV	Allows the previous dome camera to be controlled manually.
Next	NEXT	Allows the next higher number dome camera to be controlled manually.
Home	HOME	Immediately calls Home function. Deletes selected value or function in programming mode
Global	GLBL	Sends all cameras to preset (e.g., 1, 2... 55 + Enter/Glbl). 888+Enter/Glbl : Night shot mode, 999+Enter/Glbl : Normal mode
Call Preset position	PRST	Pressing Prst will bring up the preset programming menu. Recalls preset; e.g.; 1, 2... 31... 240 + Prst In the preset or tour programming mode, the operator can review the exiting preset (selected by cursor) by pressing this key.
Tour	TOUR	Pressing Tour will bring up the tour programming menu directly Recalls programmed presets or functions sequentially. (e.g., 1 ~ 8+Tour)
Pattern	PTRN	Pressing Ptrn will bring up the pattern programming menu directly. Repeats the selected pattern of the current dome camera. (e.g., 1 ~ 4+Ptrn)
Auto Scan	SCAN	Pressing Scan will bring up the Auto Scan programming menu. Calls Auto panning function (e.g., 2+Scan repeats Auto Scan 2).
Configuration	MENU	Enters programming menu. Ctrl+Menu will invoke Keyboard set up menu
Program	PGM	No.+Pgm+Prst will store current view as a preset directly. No.+Pgm+Tour will open programming menu No.+Pgm+Scan will open programming menu
Control	CTRL	Ctrl+Joystick : In a programming mode (Preset, Pattern, Scan, Privacy...) the joystick operates as if in the normal control mode. While pressing and holding down the Ctrl key, all movements of the joystick will start recording when in the pattern programming menu. Ctrl+Joystick : In normal operation mode, manual speed of the joystick control will be operated in turbo mode. (Max. speed = 380° /sec)
Enter	ENTER	Completes entering data for the password or title ENTER+Joystick : Direction key in DVR remote mode or Mux (PTZ, Mouse, Cursor)
Manual Focus		Overrides auto focus. Moving the Zoom handle reactivates Auto Focus mode.
Manual Iris		Overrides auto iris. Moving the joystick reactivates Auto Iris mode.
Zoom		Zoom control.
Joystick	Twist Up / Down Left / Right Press(Toggle)	Zoom control (proportional to position).(HID2404CZx model only). Tilt control, Cursor Up / Down in the PGM. menu Pan control, Cursor Left / Right or Page scroll in the PGM. Menu Pressing the joystick toggles between zoom control mode on and off. When zoom control mode is on, you can see "Z" letter at LCD right down corner. (joystick up : zoom in & joystick down : zoom out) (HID2404CLx model only).

3.3.2 Keys for Multiplexer

Function	Key Label	Descriptions
PiP	PIP	Picture-in-Picture mode
2 by 2 Display	2X2	Displays view of four cameras. The remaining cameras can be sequenced in the lower-right window.
3 by 3 Display	3X3	Displays view of nine cameras. The remaining cameras can be sequenced in the lower-right window.
4 by 4 Display	4X4	Displays view of 16 cameras in 1/16-size pictures.
	2ND	Second mode of PIP multiplexer. Pressing 2nd+Enter again will return to normal mode.
	L.REC	Put a camera in the Panic Record Mode.
	MACRO	Same as Menu key in the Duplexer model. Same as Macro key in the Triplexer model.
Select or Alarm	SEL	Same as Select key in the Duplexer model. Same as Alarm key in the Triplexer model.
Freeze	FRZ	Freeze the video from the currently selected camera.
Digital Zoom	ZOOM	Enter the Zoom Mode.
Sequence	SEQ	Put the multiplexer in the Sequence Mode.
VCR	VCR	Switch the multiplexer into VCR playback mode.
SET	SET	This button has several functions . It brings up a Popup Menu, sets selections on the OSD menus and decreases numbers in the number setup function.
Spot output	AUX1 (~4)	Displays selected camera as spot output of the current Multiplexer. (e.g., 2+Aux1 will display camera 2 as a spot output of the current Multiplexer)
Select Mux ID	MUX	Select Multiplexer (e.g.; 1 or 2+Mux)
Cursor movement	<u>Enter + Joystick</u>	Up / Down / Left / Right control in the ZOOM and SET UP mode. Handle turn clockwise for SET mode. Handle turn counterclockwise for ESC mode.

3.3.3 Keys for DVR

Function	Key Label	Descriptions
Id Selection		DVR ID Selection. (e.g.:1 or 2+DVR).
PTZ		Open a Pan/Tilt/Zoom screen which allows you to control properly configured cameras.
Play/Pause		Play recorded data / Pause playing.
Rewind		Play video backward at high speed. Pressing the button again toggles the playback speed

Fast Forward		Play video forward at high speed. Pressing the button again toggles the playback speed from
Stop/Preset Save		During Playback mode returns the DVR to the Live Monitoring mode.
Record/Preset Call		Set the DVR so that it is ready to record video.
Menu		Enter the Quick Setup screen. You will need to enter the administrator password to access the Quick Setup. Pressing the button also closes the current menu or setup dialog box.
Alarm		First, it will reset the DVR's outputs including the internal buzzer during an alarm. Second, it will display the event log when you are in the live monitoring mode unless there is an active alarm.
Freeze		Freeze the current live screen.
Search		Display the Search menu. Pressing the button again will exit the Search menu.
Sequence		When in the live mode, pressing the SEQUENCE button displays another full live channel sequentially. When in one of the multi-view formats, pressing this button will cause the DVR to sequence cameras in two sequence modes: "Page" and "Cameo". In the Page mode, the DVR sequences through user-defined screen layouts (pages). In the Cameo mode, the bottom, right screen to display live cameras sequentially. Pressing the SEQUENCE button while in the Sequence mode will exit the Sequence mode.
Display Mode		Toggle between different display formats. The available formats are: full, 4x4, 3x3, 2x2 and PIP.
Enter		Select a highlighted item or completes an entry that you have made.
Display Mode	CTRL+1-7,9	IDR screen mode.
Go last	CTRL + 	Go last in IDR
Go First	CTRL + 	Go first in IDR
X times Backward play	No.+ 	Fast play at x(No.) times speed in IDR
X times Forward play	No.+ 	Fast rewind at x(1-8) times speed in IDR
Shuttle ring	CTRL+ENTR+ Joystick	The Shuttle Ring only functions in the Playback mode. Turning the ring clockwise plays video forward. Turning the ring counterclockwise plays video backward.
Jog dial	CTRL+ENTR+Zoom of Joystick	The Jog Dial only functions when playback video has been paused. By turning the jog dial clockwise, you can play video forward image-by-image.

Appendix A Trouble Shooting

If problems occur, verify the installation of the camera with the instructions in this manual and with other operating equipment. Isolate the problem to the specific piece of equipment in the system and refer to the equipment manual for further information.

Problem	Possible Solution
Joystick can't control system.	1. Check that the dome camera IDs are set properly (See Figures 1 to 6). Check the polarity of the data line
Camera number does not match the multiplexer number.	1. Check the camera ID and insert the BNC cable into the proper input of the multiplexer.
Forgot password	1. Consult your supplier, distributor or service Center
Multiplexer & DVR can't work with the Joystick controller.	1. Check that the data cable for the multiplexer has the correct Pin configuration (1=1, 2=2, 3=3 8=8). 2. Check the communication menu of Multiplexer as per Pages 15 (setting Multiplexer)

Appendix B SPECIFICATION

Power Consumption	12VDC, 0.5A
Control Method	RS-485, RS-232C
Baud Rates	2400~230K bps
Operating Temperature	0°C to 50°C(32°F to 140°F)
Humidity	0 to 90%RH(non-condensing)
Storage temperature	-20°C to 60°C(-40°F to 122°F)
Dimension	Professional Joystick : 380x168x96 (HID2404CZx) Economic Joystick : 380x168x70 (HID2404CLx)
Weight	Professional Joystick : 1.2kg Economic Joystick : 1.1kg
Communication	Dome Connection : Max 32 Multiplexer Connection : Max 255 DVR Connection : Max 99

(Design and Product specifications subject to change without notice)